

FBM214 HART® Communication Input Interface Module



The FBM214 HART® Communication Input Interface Module provides eight input channels, each accepting a 4 to 20mA analog signal or a digital HART signal superimposed on a 4 to 20 mA analog input signal.

FEATURES

Key features of the FBM214 module are:

- ▶ Eight analog input channels, each accepting one of the following inputs:
 - Standard 4 to 20 mA analog sensor signal
 - Digital HART Frequency Shift Keying (FSK) signal superimposed on a 4 to 20 mA analog input signal.
- ▶ FSK modem dedicated to each input channel for bi-directional digital communications with a HART field device
- ▶ Analog to digital conversion of each of the 4 to 20 mA input signals from the HART devices
- ▶ Support for the HART universal commands necessary to interface the field device with the I/A Series® system database
- ▶ Galvanic isolation of the group of 8 input channels from ground and module logic
- ▶ Compact, rugged design suitable for enclosure in Class G3 (harsh) environments
- ▶ High accuracy achieved by sigma-delta data conversions for each channel
- ▶ Termination Assemblies (TAs) for locally or remotely connecting field wiring to the FBM214
- ▶ Termination Assemblies for per channel internally and/or externally loop powered transmitters.

OVERVIEW

The FBM214 HART Communication Input Interface Module contains eight 4 to 20 mA group isolated analog input channels. The FBM214 supports any mix of standard 4 to 20 mA devices and HART devices.

The FBM214 serves as a HART communications field device host, enabling the I/A Series system to request and receive two digital messages per second from the field device. The message pass-through capability can be used to support HART universal, common practice, and device-specific commands, but not the burst communication mode. These commands are implemented using the Intelligent Field Device Configurator (IFDC — refer to PSS 21S-8A3 B3 for details).

The FBM214 provides a common isolated power supply to power all eight channels. Optionally, the channels can be powered by an external power supply. However, when a common external power supply is used with two or more channels, a Cable Balun module is required to prevent channel cross talk.

COMPACT DESIGN

The FBM214 has a compact design, with a rugged extruded aluminum exterior for physical protection of the circuits. Enclosures specially designed for mounting the FBMs provide various levels of environmental protection, up to harsh environments per ISA Standard S71.04.

HIGH ACCURACY

For high accuracy, the module incorporates a Sigma-Delta converter which can provide new analog input values for each channel every 100 milliseconds.

VISUAL INDICATORS

Light-emitting diodes (LEDs) incorporated into the front of the module provide visual indication of the module's operational status, and communication activity on the channels.

EASY REMOVAL/REPLACEMENT

The module can be removed/replaced without removing field device termination cabling, power, or communications cabling.

FIELDBUS COMMUNICATION

A Fieldbus Communication Module or a Control Processor interfaces the redundant 2 Mbps module Fieldbus used by the FBMs. The FBM214 module accepts communication from either path (A or B) of the redundant 2 Mbps fieldbus — should one path fail or be switched at the system level, the module continues communication over the active path.

The use of an external power supply common to two or more loops requires a Cable Balun Module to maintain communication signal line balance.

MODULAR BASEPLATE MOUNTING

The module mounts on a modular baseplate which accommodates up to four or eight FBMs. The modular baseplate is either DIN rail mounted or rack mounted, and includes signal connectors for redundant fieldbus, redundant independent dc power, and termination cables.

TERMINATION ASSEMBLIES

Field input signals connect to the FBM subsystem via DIN rail mounted TAs. The TAs used with the FBM214 are described in "TERMINATION ASSEMBLIES AND CABLES" on page 8.

CABLE BALUN MODULE

The Cable Balun module is used to maintain digital communication line balance for HART Transmitter to FBM loops that are powered from a common external power supply. This powering effectively connects one line of each loop together. Without the Baluns, in each loop so powered, the common connection at the external power supply, would cause near end crosstalk at the system end of the loop wiring cable. Loops using FBM internal power source do not require Baluns.

The Cable Balun module contains multiple Baluns. One Balun segment is interconnected in each loop powered from an external power supply per the diagram above. There is one Cable Balun module.

Cable Balun Module

Module Model	Module Part No.	No. of Baluns in the Module
CBM-4	P0903SV	4

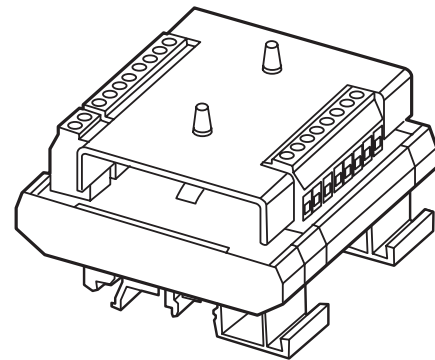
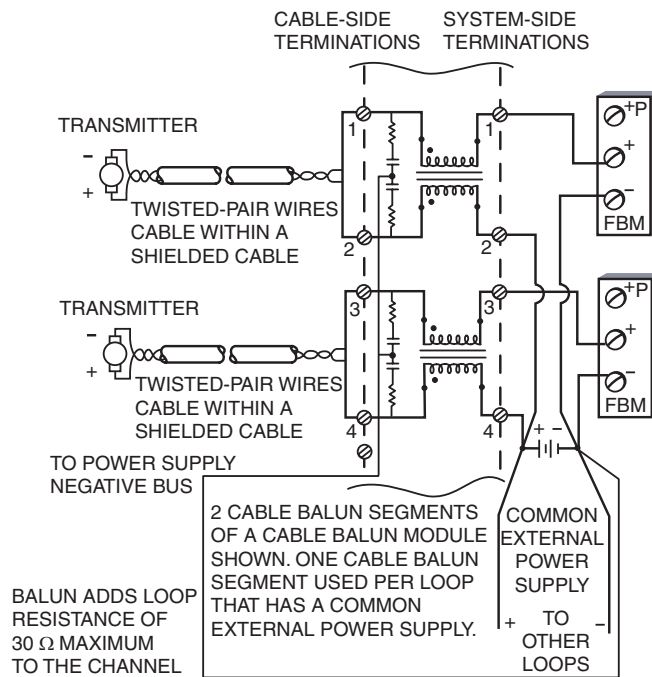

CABLE BALUN MODULE

Figure 1. Cable Balun Module

FUNCTIONAL SPECIFICATIONS

Field Device Channels

VERSION SUPPORTED

HART Protocol v6

INTERFACE

8 group-isolated channels

COMMUNICATION TO THE DEVICE

Point-to-point, master/slave, asynchronous, half-duplex, at 1200 baud.

ERROR CHECKING

Parity on each byte, and one CRC check byte.

SPEED

2 messages per second

FASTEST ALLOWED ECB BLOCK PERIOD

500 msec

MAXIMUM DISTANCE (FBM214 TO FIELD DEVICE)

Meets HART FSK physical layer specification HCF_SPEC-54, Revision 8.1 [up to 3030 m (10000 ft)]⁽¹⁾.

COMPLIANCE VOLTAGE

18 V dc minimum at 20.5 mA

CURRENT INPUTS

Sense Resistor

61.9 Ω nominal

Total Input Resistance

280 Ω minimum

Accuracy (Includes Nonlinearity)

$\pm 0.03\%$ of full scale

Temperature Coefficient

50 ppm/ $^{\circ}\text{C}$

Resolution

15 bits

Update Rate

100 ms

Integration Time

500 ms

Common Mode Rejection

>100 db at 50 or 60 Hz

Normal Mode Rejection

>35 db at 50 or 60 Hz

MAXIMUM LOOP RESISTANCE

280 Ω (not including the field device)⁽²⁾

LOOP POWER SUPPLY PROTECTION

Each channel is galvanically group isolated, current limited and voltage regulated. All inputs are limited by their design to less than 30 mA. If the current limit circuit shorts out, the current is limited to about 85 mA.

FBM INPUT IMPEDANCE

280 Ω minimum

FBM INTERNAL POWER FOR FIELD DEVICE

24 V dc $\pm 10\%$ common power supply for all channels. Loop load limited to one device per channel.

ISOLATION

The channels are not galvanically isolated from each other, but are galvanically isolated (both optical and transformer isolation) as a group from ground and module logic. Inputs use an internal FBM isolated power supply for field power. The module withstands, without damage, a potential of 600 V ac applied for one minute between the group-isolated channels and earth (ground).

CAUTION

This does not imply that these channels are intended for permanent connection to voltages of these levels. Exceeding the limits for input voltages, as stated elsewhere in this specification, violates electrical safety codes and may expose users to electric shock.

Fieldbus Communication

Communicates with its associated FCM or FCP via the redundant 2 Mbps module Fieldbus

HEAT DISSIPATION

4 W (maximum)

(1) The maximum allowable distance decreases when the loop is operated through an intrinsic safety barrier. The maximum distance of the field device from the FBM is a function of compliance voltage, wire gauge and voltage drop at the device.

(2) In an intrinsic safety application, if a zener barrier is used between the FBM and the field device, the power supply must be set at 24V dc +5%, -1%. There are no specific constraints with the use of galvanic barriers.

FUNCTIONAL SPECIFICATIONS (CONTINUED)

Power Requirements**INPUT VOLTAGE RANGE (REDUNDANT)**24 V dc $\pm 5\%$ **CONSUMPTION**

7 W (maximum)

Regulatory Compliance**ELECTROMAGNETIC COMPATIBILITY (EMC)***European EMC Directive 89/336/EEC*

Meets: EN 50081-2 Emission standard

EN 50082-2 Immunity standard

EN 61326 Annex A (Industrial Levels)

*CISPR 11, Industrial Scientific and Medical (ISM) Radio-frequency Equipment -**Electromagnetic Disturbance Characteristics**- Limits and Methods of Measurement*

Meets Class A Limits

IEC 61000-4-2 ESD Immunity

Contact 4 kV, air 8 kV

IEC 61000-4-3 Radiated Field Immunity

10 V/m at 80 to 1000 MHz

*IEC 61000-4-4 Electrical Fast**Transient/Burst Immunity*

2 kV on I/O, dc power and communication lines

IEC 61000-4-5 Surge Immunity

2kV on ac and dc power lines; 1kV on I/O and communications lines

IEC 61000-4-6 Immunity to Conducted Disturbances Induced by Radio frequency Fields

10 V (rms) at 150 kHz to 80 MHz on I/O, dc power and communication lines

IEC 61000-4-8 Power Frequency Magnetic Field Immunity

30 A/m at 50 and 60 Hz

PRODUCT SAFETY (FBM AND CABLE BALUN)*Underwriters Laboratories (UL) for U.S. and Canada*

UL/UL-C listed as suitable for use in

UL/UL-C listed Class I, Groups A-D;

Division 2; temperature code T4 enclosure

based systems. These modules are also UL

and UL-C listed as associated apparatus for

supplying non-incendive communication

circuits for Class I, Groups A-D hazardous

locations when connected to specified

I/A Series[®] processor modules as describedin the *I/A Series DIN Rail Mounted**Subsystem User's Guide* (B0400FA). Where

power is supplied by the FBM,

communications circuits also meet the

requirements for Class 2 as defined in

Article 725 of the National Electrical Code

(NFPA No.70) and Section 16 of the

Canadian Electrical Code (CSA C22.1).

Conditions for use are as specified in the

*I/A Series DIN Rail Mounted Subsystem**User's Guide* (B0400FA).*European Low Voltage Directive 73/23/EEC**and Explosive Atmospheres (ATEX) directive 94/9/EC*

CENELEC (DEMKO) certified as EEx nA IIC

T4 for use in CENELEC certified Zone 2

enclosure certified as associated apparatus

for supplying non-incendive field circuits for

Zone 2, Group IIC, potentially explosive

atmospheres when connected to specified

I/A Series processor modules as described

in the *I/A Series DIN Rail Mounted**Subsystem User's Guide* (B0400FA). Also,

see Table 1 on page 9.

Calibration Requirements

Calibration of the module or termination assembly is not required.

ENVIRONMENTAL SPECIFICATIONS⁽³⁾

Operating

TEMPERATURE

Module

-20 to +70°C (-4 to +158°F)

Termination Assembly

PVC

-20 to +50°C (-4 to +122°F)

PA

-20 to +70°C (-4 to +158°F)

RELATIVE HUMIDITY

5 to 95% (noncondensing)

ALTITUDE

-300 to +3,000 m (-1,000 to +10,000 ft)

Storage

TEMPERATURE

-40 to +70°C (-40 to +158°F)

RELATIVE HUMIDITY

5 to 95% (noncondensing)

ALTITUDE

-300 to +12,000 m (-1,000 to +40,000 ft)

Contamination

Suitable for use in Class G3 (Harsh) environments as defined in ISA Standard S71.04, based on exposure testing according to EIA Standard 364-65, Class III.

Vibration

7.5 m/S² (0.75 g) from 5 to 500 Hz

(3) The environmental limits of this module may be enhanced by the type of enclosure containing the module. Refer to the applicable Product Specification Sheet (PSS) which describes the specific type of enclosure that is to be used.

PHYSICAL SPECIFICATIONS

Mounting

MODULE

FBM214 mounts on a modular baseplate. The baseplate can be mounted on a DIN rail (horizontally or vertically), or horizontally on a 19-inch rack using a mounting kit. Refer to PSS 21H-2W6 B4 for details.

TERMINATION ASSEMBLY

The TA mounts on a DIN rail and accommodates multiple DIN rail styles including 32 mm (1.26 in) and 35 mm 1.38 in).

Mass

MODULE

284 g (10 oz) approximate

TERMINATION ASSEMBLY

Compression

181 g (0.40 lb) approximate

Ring Lug

249 g (0.55 lb) approximate

Dimensions – Module

HEIGHT

102 mm (4 in)

114 mm (4.5 in) including mounting lugs

WIDTH

45 mm (1.75 in)

DEPTH

104 mm (4.11 in)

Dimensions – Termination Assembly

See page 10.

Part Numbers

FBM214 MODULE

P0922VT

TERMINATION ASSEMBLIES

See “FUNCTIONAL SPECIFICATIONS – TERMINATION ASSEMBLIES” on page 8.

Termination Cables

CABLE LENGTHS

Up to 30 m (98 ft)

CABLE MATERIALS

Polyurethane or Hypalon®/XLP

TERMINATION CABLE TYPE

Type 1 – See Table 2 on page 9.

CABLE CONNECTION – TA

25-pin male D-subminiature

Construction – Termination Assembly

MATERIAL

Polyvinyl Chloride (PVC), compression

Polyamide (PA), compression

PVC, ring lug

FAMILY GROUP COLOR

Green – communication

TERMINAL BLOCKS

3 tiers, 8 positions

Field Termination Connections

COMPRESSION-TYPE ACCEPTED WIRING SIZES

Solid/Stranded/AWG

0.2 to 4 mm²/0.2 to 2.5 mm²/24 to 12 AWG

Stranded with Ferrules

0.2 to 2.5 mm² with or without plastic collar

RING-LUG TYPE ACCEPTED WIRING SIZES

#6 size connectors (0.375 in (9.5 mm))

0.5 to 4 mm²/22 AWG to 12 AWG

TERMINATION ASSEMBLIES AND CABLES

Field input signals connect to the FBM subsystem via DIN rail mounted Termination Assemblies, which are **electrically passive**. TAs for the FBM214 are available in the following forms:

- ▶ Compression screw type using Polyvinyl Chloride (PVC) material
- ▶ Compression screw type using Polyamide (PA) material
- ▶ Ring lug type using PVC material.

See the following “FUNCTIONAL SPECIFICATIONS – TERMINATION ASSEMBLIES” for a list of TAs used with the FBM214.

The FBM214 provides sufficient loop resistance to allow use of the HART Hand-Held Terminal, or PC20 Intelligent Field Device Configurator (PSS 2A-1Z3 E).

A removable termination cable connects the DIN rail mounted TA to the FBM via a field connector on the baseplate in which the FBM is installed. Termination cables are available in the following materials:

- ▶ Polyurethane
- ▶ Hypalon XLP.

Termination cables are available in a variety of lengths, up to 30 meters (98 feet), allowing the Termination Assembly to be mounted in either the enclosure or in an adjacent enclosure. See Table 2 for a list of termination cables used with the TAs for the FBM214.

FUNCTIONAL SPECIFICATIONS – TERMINATION ASSEMBLIES

FBM Type	Input Signal	TA Part Number		Termination	TA Cable	TA Certification
		PVC ^(a)	PA ^(a)	Type ^(b)	Type ^(c)	Type ^(d)
FBM214	8 input channels, 4 to 20 mA analog signal, alone or with HART signal superimposed	P0916BX P0926EA	P0926TD	C RL	1	1, 2

(a) PVC is polyvinyl chloride rated from -20 to +50°C (-4 to +122°F). PA is Polyamide rated from -20 to +70°C (-4 to +158°F).
 (b) C = TA with compression terminals; RL = TA with ring lug terminals.
 (c) See Table 2 for cable part numbers and specifications.
 (d) See Table 1 for Termination Assembly certification definitions.

Table 1. Certification for Termination Assemblies

Type	Certification ^(a)
Type 1	TAs are UL/UL-C listed as suitable for use in Class I; Groups A-D; Division 2 temperature code T4 hazardous locations. They are CENELEC (DEMKO) certified EEx nA IIC T4 for use in Zone 2 potentially explosive atmospheres.
Type 2	TAs are UL/UL-C listed as associated apparatus for supplying non-incendive field circuits Class I; Groups A-D; Division 2 hazardous locations when connected to specified DIN rail mounted FBMs and field circuits meeting entity parameter constraints specified in <i>DIN Rail Mounted Subsystem User's Guide</i> (B0400FA). They are also CENELEC (DEMKO) certified as associated apparatus for supplying field circuits for Group IIC, Zone 2 potentially explosive atmospheres. Field circuits are also Class 2 limited energy (60 V dc, 30 V ac, 100 VA or less) if customer-supplied equipment meets Class 2 limits.

(a) All TAs are UL/UL-C listed to comply with applicable ordinary location safety standards for fire and shock hazards. Hazardous location types comply with ATEX directive for II 3 G use. They also comply with the requirements of the European Low Voltage Directive. All listings/certifications require installation and use within the constraints specified in *DIN Rail Mounted Subsystem User's Guide* (B0400FA) and the conditions stated in UL and DEMKO reports.

Table 2. Cables Types and Part Numbers

Cable Length m (ft)	Type 1 P/PVC ^(a)	Type 1 H/XLPE ^(b)	Cable Length m (ft)	Type 1 P/PVC ^(a)	Type 1 H/XLPE ^(b)
0.5 (1.6)	P0916DA	P0916VA	10.0 (32.8)	P0916DE	P0916VE
1.0 (3.2)	P0916DB	P0916VB	15.0 (49.2)	P0916DF	P0916VF
2.0 (6.6)	P0931RM	P0931RR	20.0 (65.6)	P0916DG	P0916VG
3.0 (9.8)	P0916DC	P0916VC	25.0 (82.0)	P0916DH	P0916VH
5.0 (16.4)	P0916DD	P0916VD	30.0 (98.4)	P0916DJ	P0916VJ

(a) P/PVC is polyurethane outer jacket and semi-rigid PVC primary conductor insulation.

(b) H/XLPE is Hypalon outer jacket and XLPE (cross-linked polyethylene) primary conductor insulation.

DIMENSIONS – NOMINAL

[mm]
in

Compression Termination Assembly

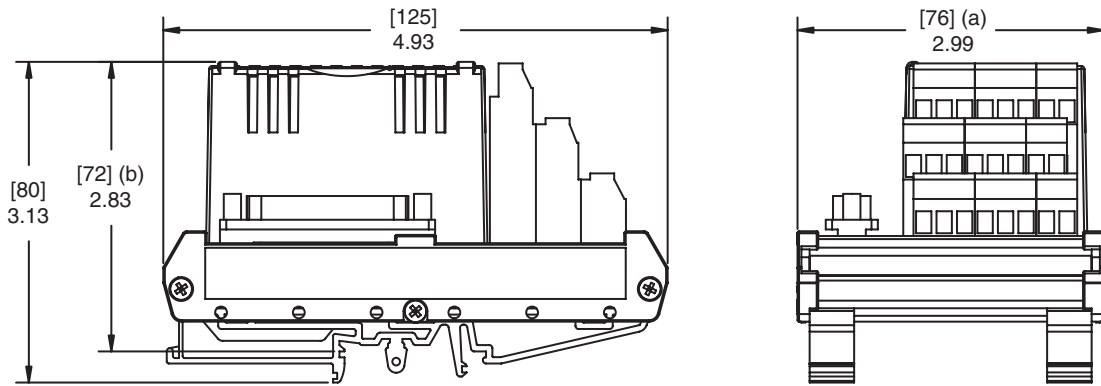

Ring Lug Termination Assembly

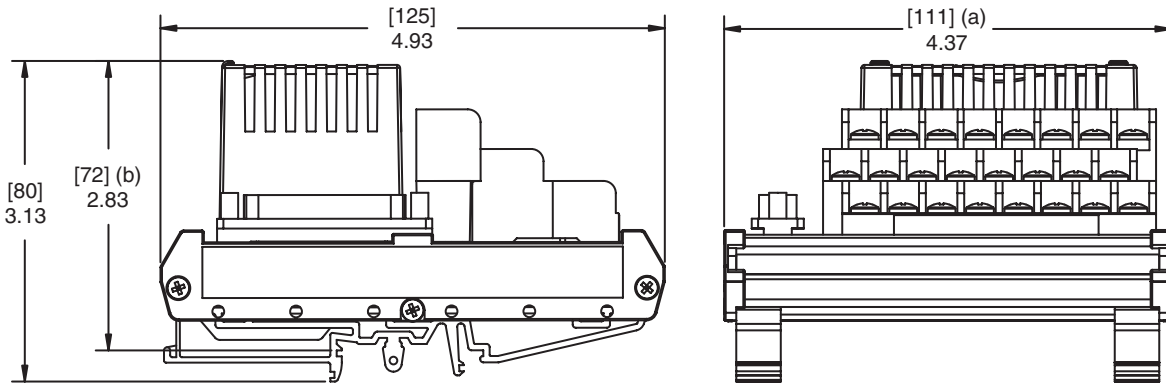

- (a) Overall width – for determining DIN rail loading.
- (b) Height above DIN rail (add to DIN rail height for total).

RELATED PRODUCT SPECIFICATION SHEETS

PSS Number	Description
PSS 21H-2W1 B3	DIN Rail Mounted FBM Subsystem Overview
PSS 21H-2W2 B3	DIN Rail Mounted FBM Equipment, Agency Certifications