

## 10.2.6—Troubleshooting

Each I/O module has a red fault LED, which indicates the status of the module. This LED will help with troubleshooting if the module should have a problem. A solid red LED indicates that the actuator controller is not communicating with the CPU module. Flashing red LEDs indicate an internal problem with the module, and module replacement is recommended.

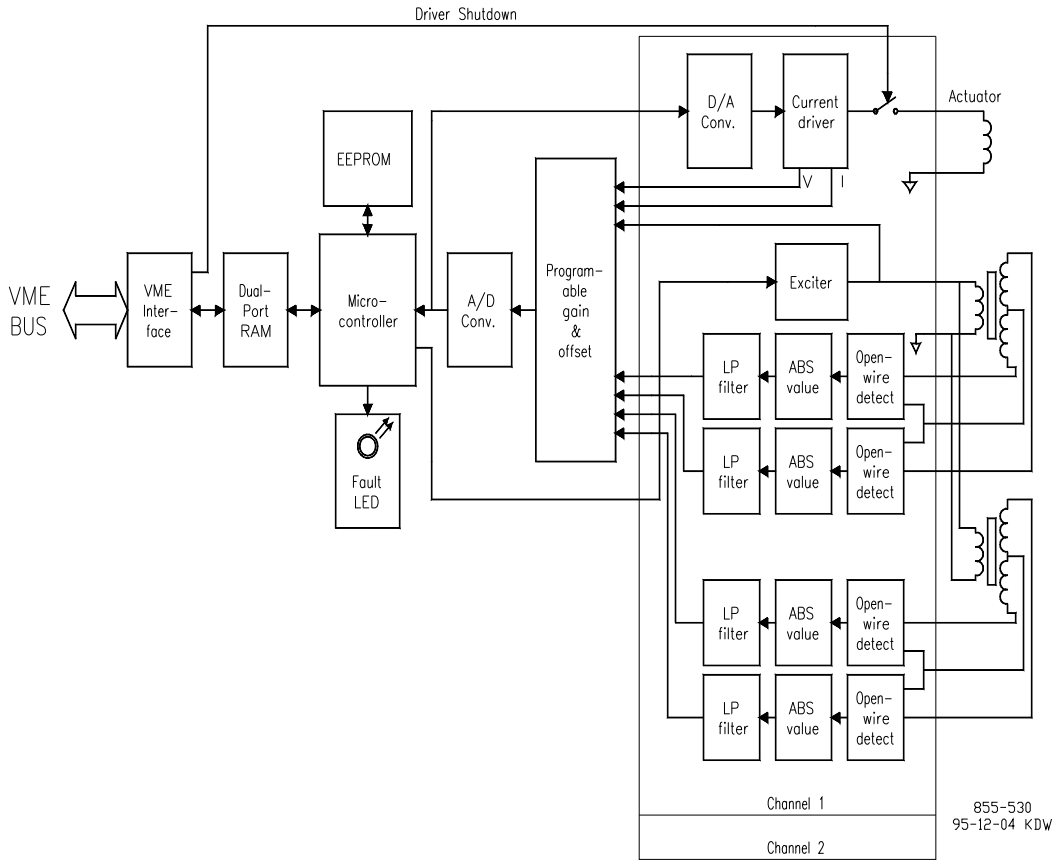

Figure 10-4—Two Channel Actuator Controller Module Block Diagram

## 10.3—Four Channel Actuator Module

### 10.3.1—Module Description

This Actuator Driver module receives digital information from the CPU and generates four proportional actuator-driver signals. These signals are proportional and their maximum range is 0 to 25 mAdc or 0 to 200 mAdc.

Figure 10-5 is a block diagram of the four-channel Actuator Driver module. The system writes output values to dual-port memory through the VME-bus interface. The microcontroller scales the values using calibration constants stored in EEPROM, and schedules outputs to occur at the proper time.

The microcontroller monitors the output voltage and current of each channel and alerts the system of any channel and load faults. The system can individually disable the current drivers. If a fault is detected which prevents the module from operating, by either the microcontroller or the system, the FAULT LED will illuminate.

This module requires no calibration; an actuator may be replaced with a like actuator without any module or software adjustment.



Figure 10-5—Four Channel Actuator Driver Module

### 10.3.2—Module Specification

Output Current Ranges:	0–25 mA, 0–200 mA
Resolution:	12 bits
Accuracy @ 25 °C:	0.1% of full scale
Drift:	150 ppm/°C
Maximum Actuator Resistance:	45 Ω @ 200 mA, 360 Ω @ 25 mA
Maximum Actuator Inductance:	1 H
Dither:	Tunable amplitude, 25 Hz square wave
Analog Driver Bandwidth:	50 Hz minimum
<b>Fault Detection:</b>	
Load Faults:	Module monitors actuator impedance
Driver Faults:	Actuator current is interrupted if fault is detected
Microcontroller Faults:	System monitors a software watchdog
System Faults:	Actuator current is interrupted if communications with CPU are lost
Shutdowns:	Current in each channel may be individually interrupted

### 10.3.3—Installation

The modules slide into card guides in the control's chassis and plug into the motherboard. The modules are held in place by two screws, one at the top and one at the bottom of the front panel. Also at the top and bottom of the module are two handles which, when toggled (pushed outward), move the modules out just far enough for the boards to disengage the motherboard connectors.

### 10.3.4—FTM Reference

See Chapter 13 for complete field wiring information for the Four Channel Actuator Module FTM. See Appendix A for part number cross reference for modules, FTMs, and cables.

### 10.3.5—Troubleshooting

Each I/O module has a red fault LED, which indicates the status of the module. This LED will help with troubleshooting if the module should have a problem. A solid red LED indicates that the actuator controller is not communicating with the CPU module. Flashing red LEDs indicate an internal problem with the module, and module replacement is recommended.

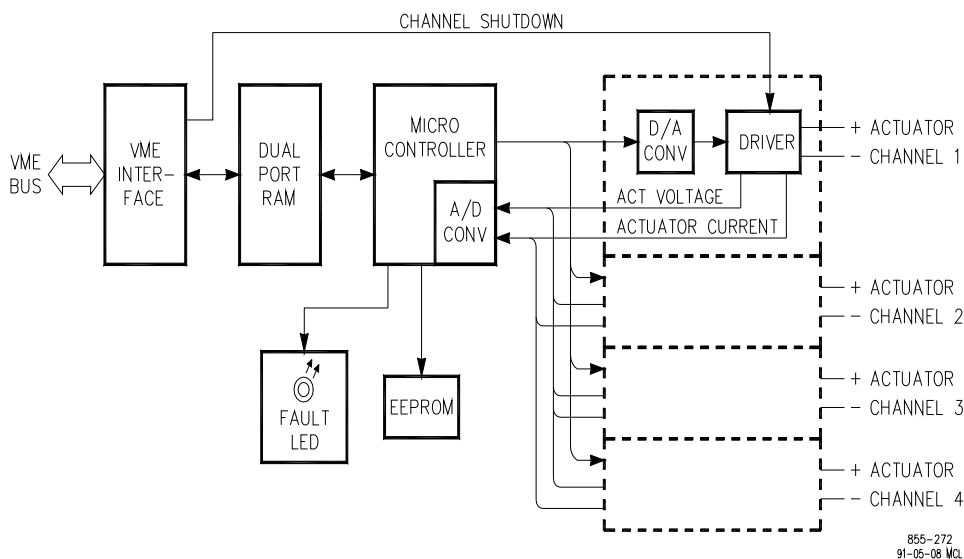

Figure 10-6—Four Channel Actuator Driver Module Block Diagram

## 10.4—Simplex Real Time SIO

### 10.4.1—Module Description

Each Real Time SIO Module contains the circuitry for three RS-485 ports. Each port is designed to communicate with EM or GS/LQ Digital Actuator Drivers. For each port, one driver is allowed for every 5 ms. Each driver is identified by its address switches, which must match the driver number in the GAP application program. The RS-485 communications to the Universal Digital Drivers can be used for monitoring or control purposes.

The Real Time SIO Module features:

- 5 ms update rate for critical parameters, with one driver per port
- Digital Actuator Driver interface

Part No	Status	Description	Extended Description	CSA	UL	ATEX	CE (LVD)	CE (EMC)	ABS	DNV	LRS
5466-257	A	MODULE	HIGH DENSITY ANALOG I/O (TMR)	x					x	x	x
5466-258	A	MODULE	SIMPLEX DISCRETE I/O	x		x	n/a	x	x	x	x
5466-260	ANP	MODULE	NETCON IIIB REAL TIME SIO VER2.06								
5466-272	ANP	MODULE	NETCON DUAL SOLENOID MONITOR								
5466-285	A	MODULE	SOLENOID PROTECTION 4CHANNEL 18-30VDC								
5466-315	A	MODULE	HIGH DENSITY ANALOG I/O	x		x	n/a	x	x	x	x
5466-316	A	MODULE	ANALOG COMBO	x			n/a	x	x	x	x
5466-318	A	MODULE	MICRONET TMR KERNEL P.S.	x			n/a	x			
5466-320	A	MODULE	SOLENOID PROTECTION 4CHANNEL 18-30VDC								
5466-326	A	MODULE	NETCON IIIB PRESSURE INPUT	x		x	n/a	x	x	x	x
5466-328	A	MODULE	NETCON IIIB 3-9 PIN RT SIO	x		x	n/a	x	x	x	x
5466-332	A	MODULE	HIGH DENSITY ANALOG I/O	x		x	n/a	x	x	x	x
5466-344	ANP	MODULE	POSITION CONTROLLER EM DFB	x			n/a	x	x	x	x
5466-345	ANP	MODULE	POSITION CONTROLLER EM SFB	x			n/a	x			
5466-348	A	MODULE	NETCON 5000B SIO	x		x	n/a	x	x	x	x
5466-350	ANP	MODULE	NETCON CPU_060								
5466-351	ANP	MODULE	NETCON CPU_040 WITH LL MEMORY	x							
5466-352	ANP	MODULE	NETCON CPU_040 W/O LL MEMORY	x			n/a	x			
5466-353	A	MODULE	NETCON MAIN CHASSIS TR	x			n/a	x	x	x	x
5466-354	A	MODULE	NETCON REMOTE CHASSIS TRANSCEIVER	x			n/a	x			
5466-355	A	MODULE	NETCON REMOTE CHASSIS TRANSCEIVER	x			n/a	x	x	x	x
5466-400	A	MODULE	ISO 4-20 ANALOG INPUT	x							
5466-404	A	MODULE	DIGITAL SPEED SENSOR	x							
5466-405	ANP	MODULE	DIGITAL SPEED SENSOR								
5466-407	A	MODULE	PENTIUM 233MHZ CPU (W/O OP-SYS)	x			x		x	x	x
5466-409	INA	MODULE	MICRONET PENTIUM CPU, 233MHZ, 64MB RAM, NT4.0				n/a	x		x	x
5466-411	A	MODULE	MICRONET ETHERNET (RJ45)	x			n/a	x	x		x
5466-416	INA	MODULE	MICRONET PENTIUM WITH DUAL ETHERNET OPTION	x			n/a	x	x	x	x
5466-419	INA	MODULE	NETCON PENTIUM CPU, 233MHZ, 128MB RAM, NT4.0, RTX4.3.2.1	x							
5466-425	A	MODULE	HIGH DENSITY ANALOG I/O (TMR)	x		x	n/a	x		x	x
5466-1000	A	MODULE	POWER SUPPLY, 2 SLOT, 24VDC INPUT, MICRONET-PLUS	x		x	x	x	x	x	
5466-1001	A	MODULE	POWER SUPPLY, 2 SLOT, 110VAC/125VDC	x		x	x	x	x	x	