

Main Processor Modules

Model 3008 Main Processors are available for Tricon v9.6 and later systems. For detailed specifications, see the *Planning and Installation Guide for Tricon Systems*.

Three MPs must be installed in the main chassis of every Tricon system. Each MP independently communicates with its I/O subsystem and executes the user-written control program.

Sequence of Events (SOE) and Time Synchronization

During each scan, the MPs inspect designated discrete variables for state changes known as *events*. When an event occurs, the MPs save the current variable state and time stamp in the buffer of an SOE block.

If multiple Tricon systems are connected by means of NCMs, the time synchronization capability ensures a consistent time base for effective SOE time-stamping. See [page 70](#) for more information.

Diagnostics

Extensive diagnostics validate the health of each MP, I/O module and communication channel. Transient faults are recorded and masked by the hardware majority-voting circuit. Persistent faults are diagnosed and the errant module is hot-replaced.

MP diagnostics perform these tasks:

- Verify fixed-program memory and static RAM

- Test all basic processor and floating-point instructions and operating modes
- Validate user memory by means of the TriBus hardware-voting circuitry
- Verify the shared memory interface with each I/O communication processor and channel
- Verify handshake and interrupt signals between the CPU, each I/O communication processor and channel
- Check each I/O communication processor and channel microprocessor, ROM, shared memory access and loopback of RS-485 transceivers
- Verify the TriClock and TriBus interfaces

Physical Description of Model 3008 Main Processors

Feature	Description
Microprocessor	Motorola MPC860, 32 bit, 50 MHz
Memory	<ul style="list-style-type: none"> • 16 MB DRAM (non-battery backed-up) • 32 KB SRAM, battery backed-up • 6 MB Flash PROM
Tribus Communication Rate	<ul style="list-style-type: none"> • 25 megabits per second • 32-bit CRC protected • 32-bit DMA, fully isolated
I/O Bus and Communication Bus Processors	<ul style="list-style-type: none"> • Motorola MPC860 32 bit 50 MHz

Indicators on Main Processors

PASS	Module has passed self-diagnostic tests
FAULT	Module has a fault and should be replaced
ACTIVE	Module is executing the user-written control program
MAINT1	Maintenance indicator 1
MAINT2	Maintenance indicator 2
COM TX	Transmitting data across COMM bus
COM RX	Receiving data from COMM bus
I/O TX	Transmitting data across I/O bus
I/O RX	Receiving data from I/O bus

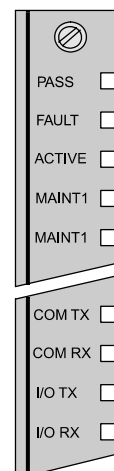

Product Specifications

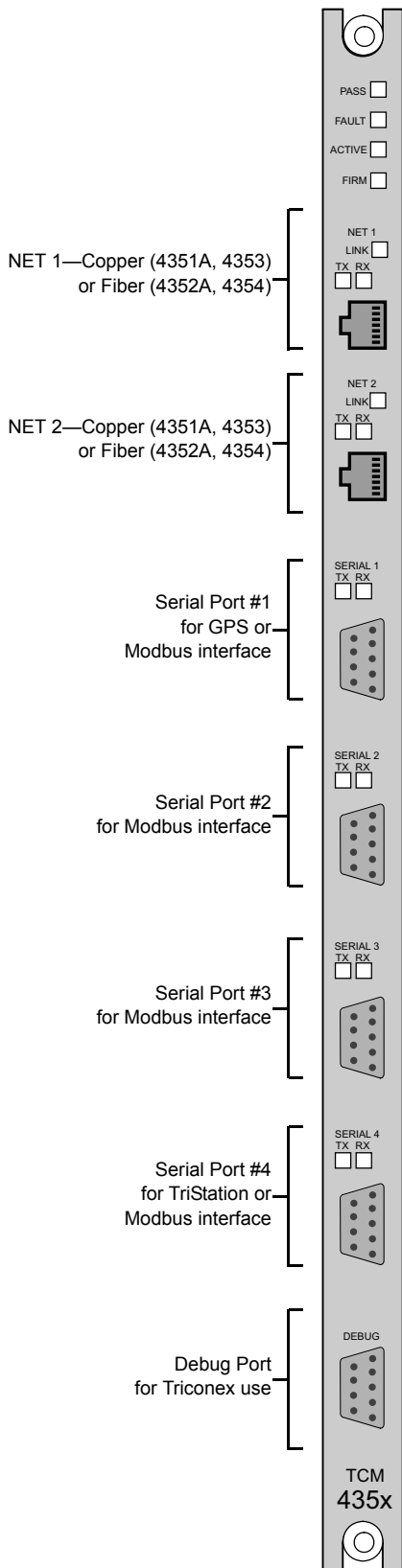

Tricon Communication Module

The Tricon Communication Module (TCM), which is compatible with only Tricon v10.0 and later systems, allows the Tricon to communicate with TriStation, other Tricon or Trident controllers, Modbus master and slave devices, and external hosts over Ethernet networks.

Each TCM contains four serial ports, two network ports, and one debug port (for Triconex use).

Each serial port is uniquely addressed and can be configured as a Modbus master or slave. Serial port #1 supports either the Modbus or the Trimble GPS interface. Serial port #4 supports either the Modbus or the TriStation interface. Each TCM supports an aggregate data rate of 460.8 kilobits per second, for all four serial ports.

Programs for the Tricon use variable names as identifiers but Modbus devices use numeric addresses called *aliases*. Therefore, an alias must be assigned to each Tricon variable name that will be read by or written to a Modbus device. An alias is a five-digit number which represents the Modbus message type and the address of the variable in the Tricon. An alias number is assigned in TriStation.

Any standard Modbus device can communicate with the Tricon through the TCM, provided that aliases are assigned to the Tricon variables. Alias numbers must also be used when host computers access the Tricon through other communication modules. See “Communication Capabilities” on page 59 for more information.

Each TCM contains two network ports—NET 1 and NET 2. Models 4351A and 4353 have two copper Ethernet (802.3) ports and Models 4352A and 4354 have two fiber-optic Ethernet ports. NET 1 and NET 2 support the TCP/IP, Modbus TCP/IP Slave/Master, TSAA, TriStation, SNTP, and Jet Direct (for network printing) protocols. NET 1 also supports the Peer-to-Peer and Peer-to-Peer Time Synchronization protocols.

A single Tricon system supports a maximum of four TCMs, which must reside in two logical slots. Different TCM models cannot be mixed in one logical slot. Each Tricon system supports a total of 32 Modbus masters or slaves—this total includes network and serial ports. The hot-spare feature is not available for the TCM, though you *can* replace a faulty TCM while the controller is online.

TCM Specifications

Model Number	4351A, 4352A, 4353, 4354	
Serial ports	4, RS-232/RS-485 ports, DB-9 connectors	
Network ports	2, 10/100BaseT Ethernet ports, RJ-45 connectors (model 4351A and 4353) 2, fiber-optic mode Ethernet ports, MTRJ connectors with 62.5/125 um fiber cables (model 4352A and 4354)	
Port isolation	500 VDC	
Protocols	TriStation, Modbus, TCP/IP, ICMP, SNTP, TSAA, Trimble GPS, Peer-to-Peer, Peer-to-Peer Time Synchronization, Jet Direct (network printing)	
Modbus functions supported	01 — Read Coil Status 02 — Read Input Status 03 — Read Holding Registers 04 — Read Input Registers 05 — Modify Coil Status	06 — Modify Register Content 07 — Read Exception Status 08 — Loopback Diagnostic Test 15 — Force Multiple Coils 16 — Preset Multiple Registers
Communication speed	Copper Ethernet ports: 10/100 Mbps Fiber Ethernet ports: 100 Mbps Serial ports: up to 115.2 Kbps per port	
Status Indicators	PASS, FAULT, ACTIVE, FIRM LINK— 1 per network port, TX (Transmit) — 1 per port, RX (Receive) — 1 per port	