

UNITROL® 6000 PSS Standalone

Enhance your excitation system to comply with Grid Code regulations at minimal cost



- Extend the life cycle of your current excitation system by adding functionality, fast and simple
- Advanced solutions and services to comply with local grid codes regulations
- Reliable product with highest availability
- Worldwide network of UNITROL® specialists at your service

01 UNITROL® 6000 PSS Standalone Main Controller

The challenge

Grid codes are constantly changing due to the new and unprecedented network developments. Therefore, installed plant equipment requires to be upgraded/replaced to comply with the network regulations which leads to increased extended outages and costs. PSS SA is a cost-effective solution to be compliant immediately.

Why Power System Stabilizer Standalone (PSS SA)

Power system stabilizers (PSS) are commonly used to damp various types of oscillation modes, as from interarea oscillations in large transmission networks to local oscillation modes of synchronous generating units. This is done by adding a stabilizing signal to the voltage regulator of the existing excitation systems.



Extend life cycle by adding functionality



Comply with local grid codes



Reliable product with highest availability



Worldwide service network

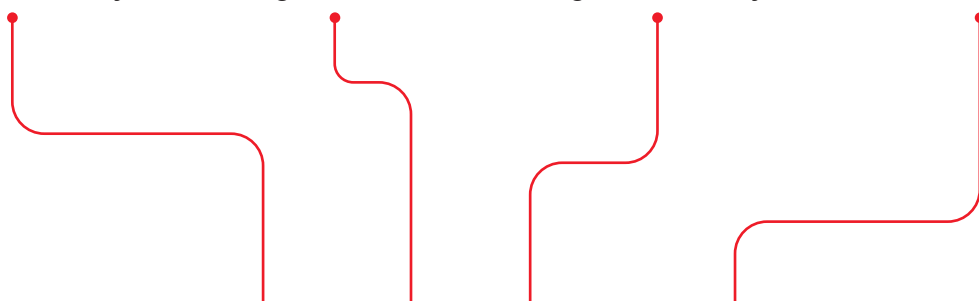

The comprehensive and flexible solution: ABB's UNITROL® 6000 Power System Stabilizer Standalone

Extend the life cycle of your current excitation system by adding functionality, fast and simple

- For any excitation brand – Indirect or Static excitation systems
- Extending the life cycle of your current system and enabling compliance with today's complex grid code regulations
- Full Power System Stabilizer (PSS) functionalities according latest IEEE421.5 standards (PSS 2A/2B/2C or 4B/4C)

Advanced solutions and services to comply with the grid codes regulations

- Build-in signal injections and high-end recording features to support
 - System identification (of Generator and Grid), even when no dynamic Model data is available from the OEMs
 - Fast and efficient capturing of network disturbances, supporting post-mortem analysis of large-scale network events and prove related unit compliance (e.g. NERC MOD-026-1)
 - Post-mortem analysis of failure on the complete gen-set.
- Adaptive PSS (APSS), with a patented grid observer, which optimizes the PSS settings based on actual network and operation conditions.
- Advanced Speed measurement algorithms based on dynamic generator models to improve PSS performance during interarea and local modes
- Dedicated RoCoF (Rate of Change of Frequency) PSS Blocking function to block PSS during large scale grid frequency changes, to avoid malfunctions.
- Designated filter networks to avoid torsional interactions, and risks of mechanical damages

Block diagram of a typical installation

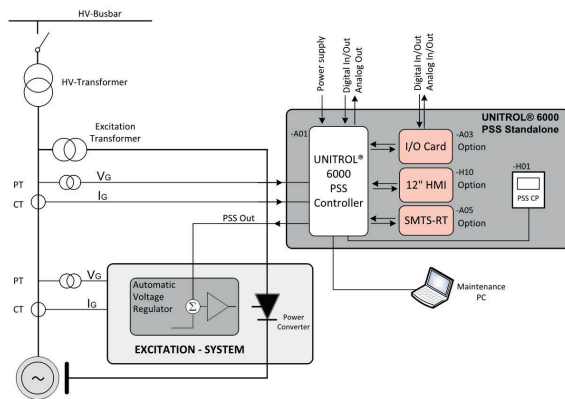

Reliable product with highest availability

- Based on UNITROL® 6000 X-power control devices, with proven track records
- Options for redundant configurations
- Extended IOs, as DCS interface and special configurations (e.g. for Pump storage with PSS operation in generating and pump mode)
- Dedicated touch screen HMI Interface to have control and monitoring at your fingertips.

Worldwide network of UNITROL® specialists is at your service

Installation and commissioning

- The professionalism, extensive experience and multilingual skills of ABB's engineers ensure a satisfactory installation and commissioning.

Power System simulation services

- Advanced services to represent and simulate the power plant in a digital environment (e.g. PowerFactory)
- Optimizations of PSS settings according to local grid code requirements
- Full grid connection and plant performance simulation studies

For more information, please contact:
 ABB Switzerland Ltd
 Power Electronics
 CH-5300 Turgi/Switzerland
 Phone: +41 58 589 38 09
 E-Mail: pes@ch.abb.com

new.abb.com/power-electronics/excitation-and-synchronization

We reserve the right to make technical changes or modify the contents of this document without prior notice. With regard to purchase orders, the agreed particulars shall prevail. ABB does not accept any responsibility whatsoever for potential errors or possible lack of information in this document.

We reserve all rights in this document and in the subject matter and illustrations contained therein. Any reproduction, disclosure to third parties or utilization of its contents – in whole or in parts – is forbidden without prior written consent of ABB.
 Copyright© 2020 ABB
 All rights reserved